

d line

Jyllingevej 59, kld
2720 København
Denmark

dline.com
support@dline.com

dline

Flush plate

For Geberit Omega 112/98/82 cm
Mounting instruction

ne dline

1

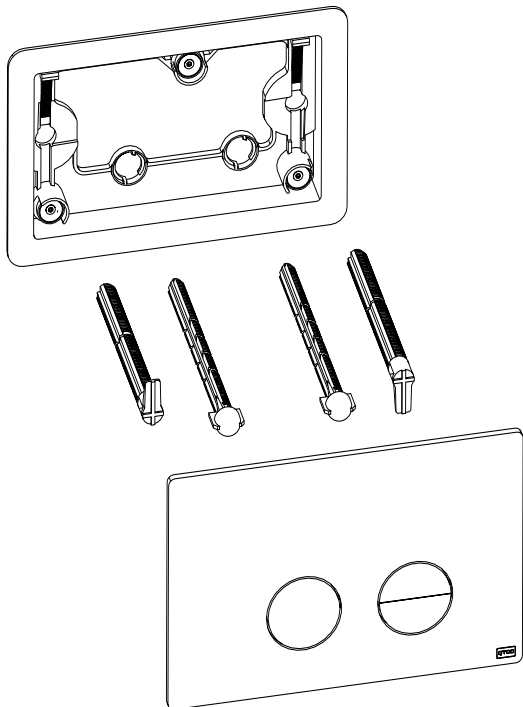

2

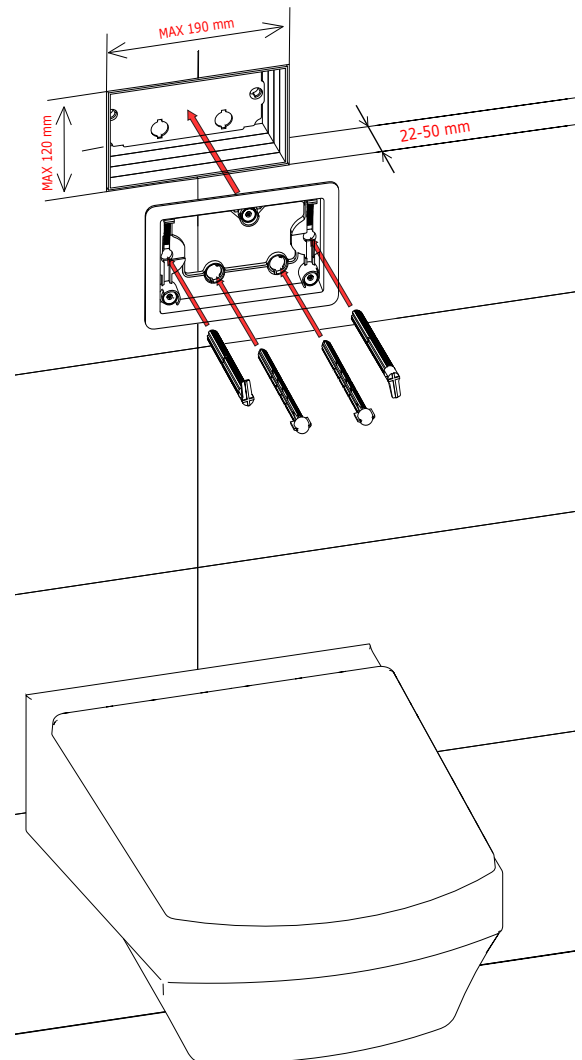

3

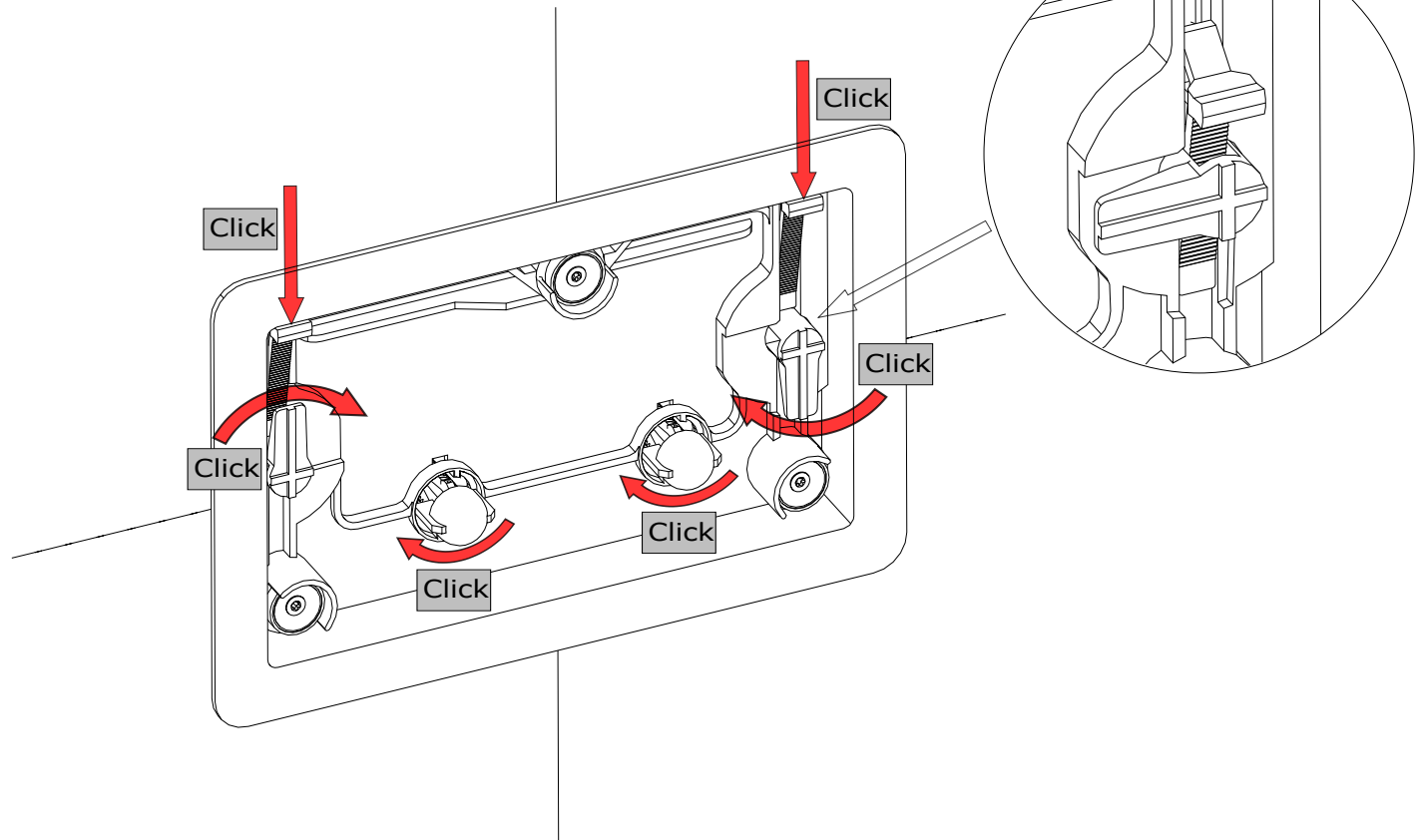

4

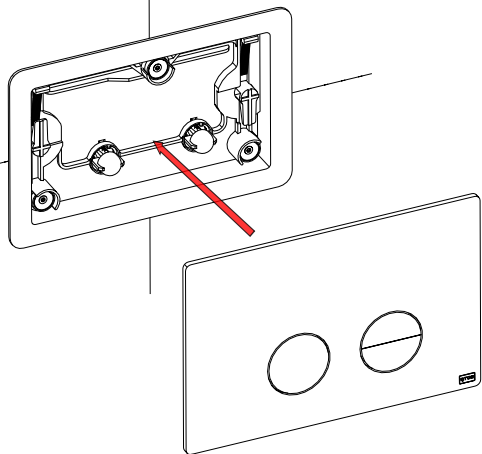

5

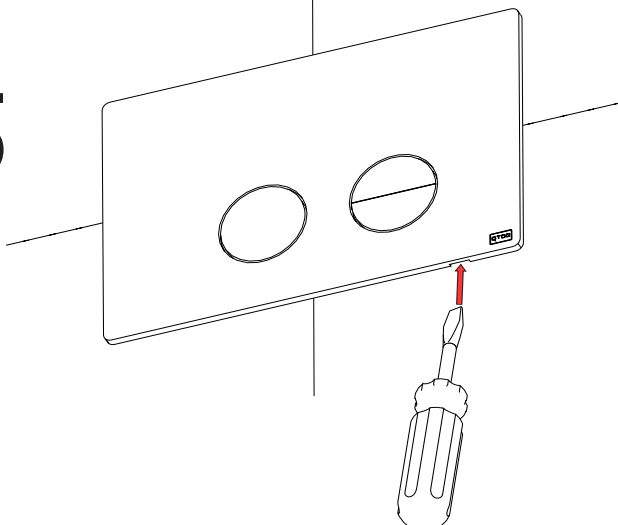

Maintenance guide Stainless steel

d line products are produced in the high quality stainless steel or brass. To sustain the unique d line finish please follow the below instructions:

- Products must always be cleaned along the structure (grinding/polishing direction), not across.
- A clean dust and grit-free cloth should be used to avoid scratching.
- Fingerprints, residue and other marks may be cleaned with soapy water or special mild detergent with a soft cloth or piece of suede.
- Always rinse off thoroughly with clean water.
- To complete the cleaning procedure dry/polish the surfaces with a soft dry cloth.
- To achieve a more authentic 'aged' look of the brass product, avoid frequent polishing, and when polishing apply pressure only to the raised surfaces (brass will change its look over time).

Do not use:

- Do not use scouring powder, because it may scratch the surface.
- Do not use cleaners containing chlorides (especially hydrochloric acid) or other aggressive cleaning products to clean stainless steel surfaces. If such products are accidentally used, wash the surface with fresh water and clean with special cleaners removing oxides and other compounds.
- Do not use cleaning agents used for cleaning silver.
- Do not use rough and abrasive materials like steel wool.

Powder coated stainless steel

- Wipe dry with a soft dry cloth. Do not use abrasive cleaning pads.
- Avoid all abrasive and aggressive chemicals.
- Avoid ammoniated products.
- Avoid bleach.

PVD coated stainless steel

- PVD coatings may fingerprint, this can be removed by washing in soap and water and dry.
- Coarse abrasives, files, or other hard objects must not be used against PVD coated stainless steel surfaces – the soft stainless steel may deform.
- If a softer metal, such as a ring or key marks the surface, it is most likely the soft metal residue that has been left on the coated surface. Clean off with soapy water or special mild detergent.